

DO NOT SCALE

3rd ANGLE PROJECTION

IF IN DOUBT ASK

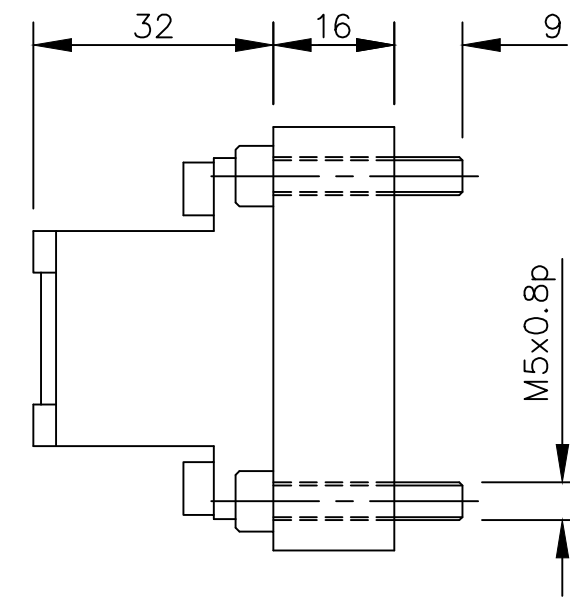
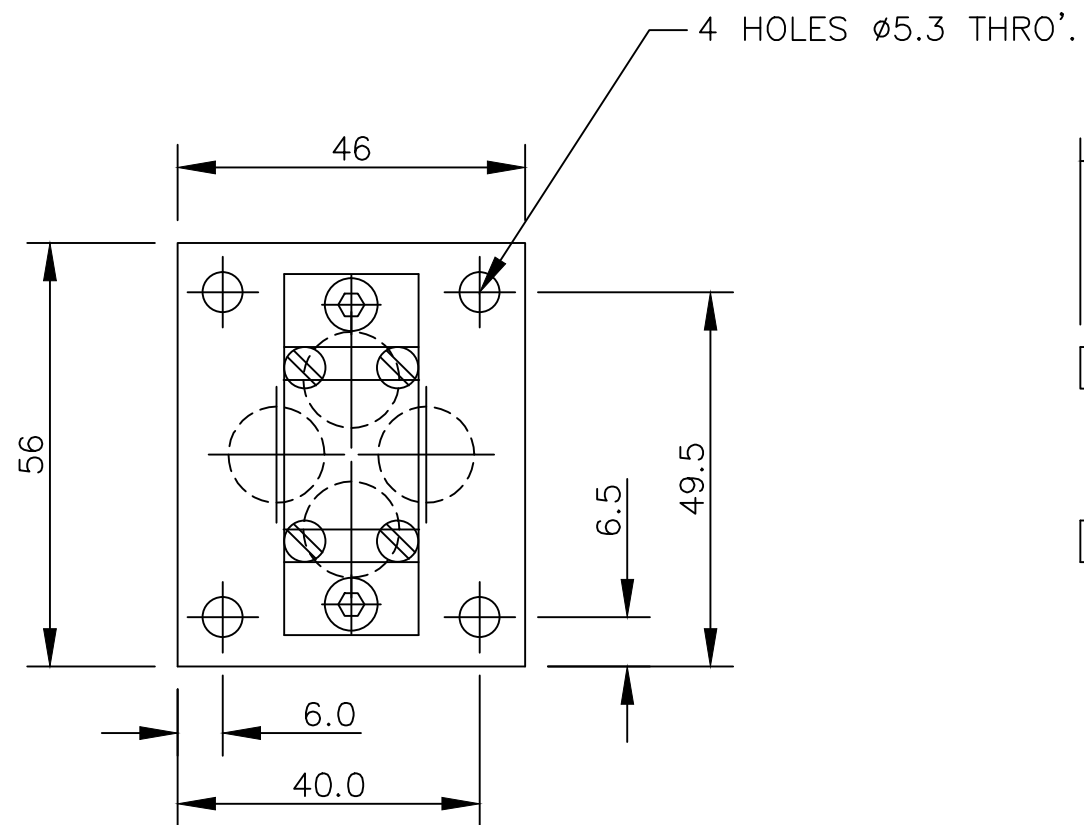
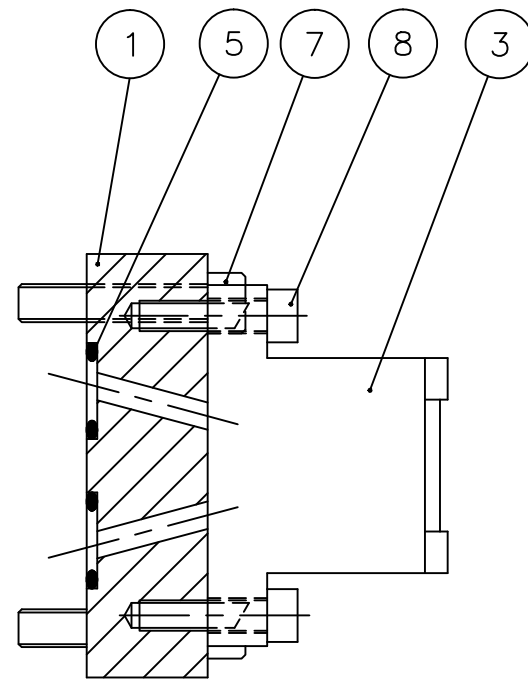
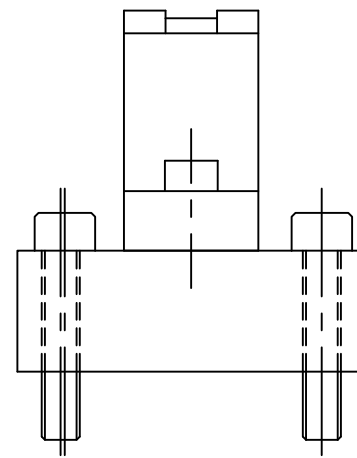
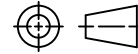
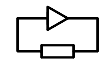

GEOMETRIC CHARACTERISTIC SYMBOLS		FEATURE CONTROL SYMBOL	
maximum material condition	perpendicularity	tolerance gt mmc. as required	Form positional tolerances & related datum are regardless of feature size unless specified.
runout	parallelism		
flatness of a surface	concentricity		
straightness of a line	symmetry		
profile of a surface	angularity		
profile of a line	roundness		
true position	basic dimension		
cylindricity	datum		

ISSUE	DATE	DESCRIPTION	JOB No	DRAWN
1	13/3/01	ORIGINAL ISSUE	GENL	R.P.B.

All Dimensions in millimetres & refer to finished sizes
 Tolerances:-
 No decimal places ±0.4
 One decimal place ±0.1
 Angular ±0.5°
 Squareness 0.1 per 100mm
 hole depths to drill point
 Surface texture 3.2um
 Remove all burrs & break sharp edges rad 0.1/0.5 unless otherwise stated

SERVOTEST © 2001	
TITLE PRESS TRANS AND MOUNT ASSY	
MATERIAL	FINISH
DATE 13/3/01	SCALE 1:1
DRN R.BAILEY	CHKD.
DRN.No D000-0388	