

DO NOT SCALE

3rd ANGLE PROJECTION

IF IN DOUBT ASK

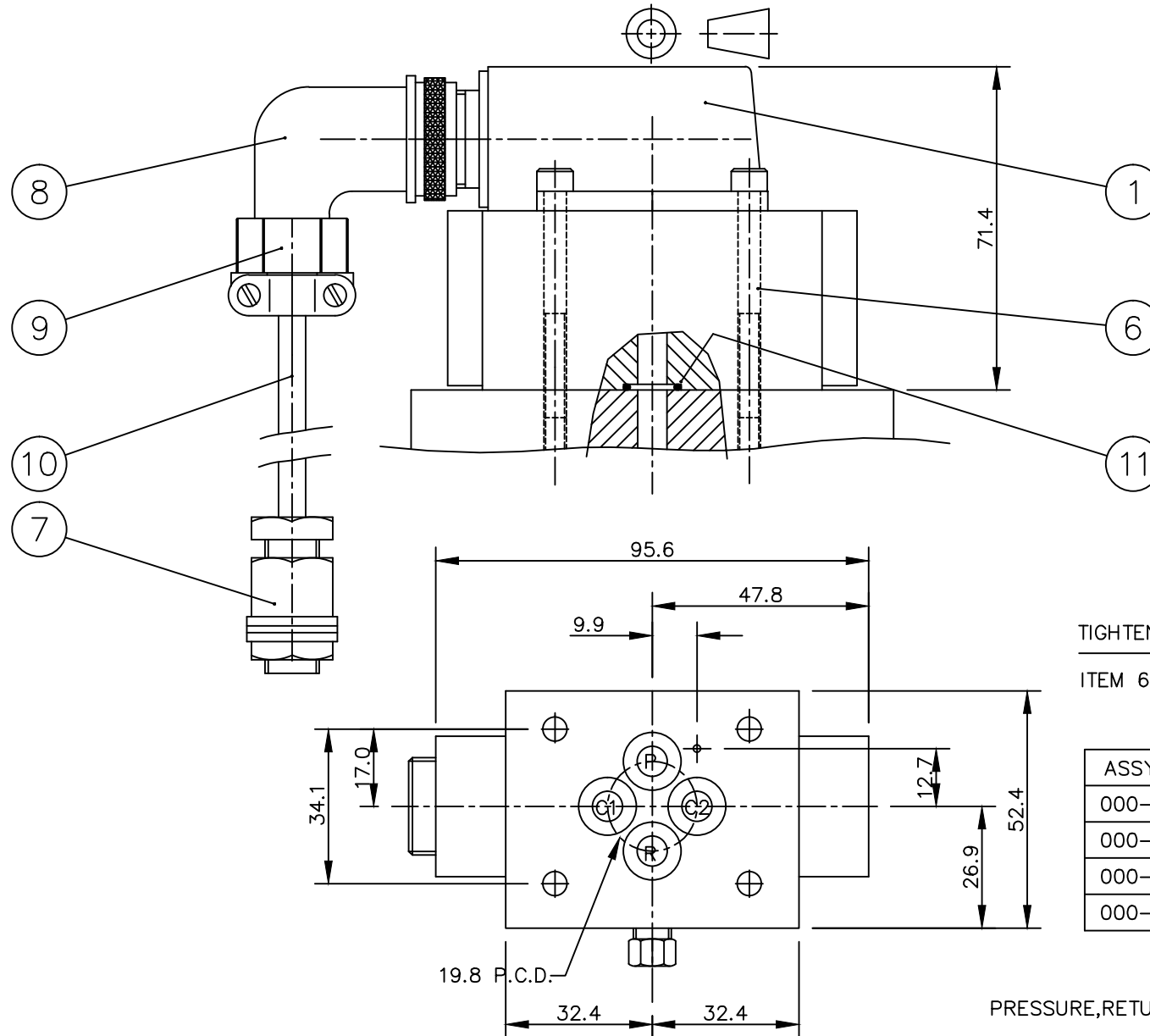

TIGHTENING TORQUE

ITEM 6 (M5) – 8 Nm

ASSY REF	DESCRIPTION
000-1396	SERVOVALVE ASSY (SV5)
000-1397	SERVOVALVE ASSY (SV10)
000-1398	SERVOVALVE ASSY (SV19)
000-1399	SERVOVALVE ASSY (SV38)

PRESSURE, RETURN AND CONTROL PORTS $\phi 6.6$

<p>GEOMETRIC CHARACTERISTIC SYMBOLS</p> <ul style="list-style-type: none"> Ⓜ maximum material condition Ⓢ runout Ⓛ flatness of a surface — straightness of a line Ⓢ profile of a surface Ⓢ profile of a line \perp perpendicularity ⊕ true position Ⓢ cylindricity Ⓢ basic dimension A datum Ⓢ parallelism Ⓢ concentricity Ⓢ symmetry Ⓢ angularity Ⓢ roundness 	<p>FEATURE CONTROL SYMBOL</p> <p>total tolerance diameter</p> <p>datum reference</p> <p>geometric characteristic symbol</p> <p>tolerance at mm. as required</p> <p>Form positional tolerances & related datum are regardless of feature size unless specified.</p>	<p>ISSUE</p> <p>1 08/10/91 ORIGINAL ISSUE</p> <p>2 30/11/01 DIMENSIONS AND PORT DETAILS ADDED.</p> <p>3</p> <p>4</p> <p>5</p> <p>6</p> <p>7</p> <p>8</p> <p>9</p>	<p>DATE</p> <p>08/10/91</p> <p>30/11/01</p> <p></p> <p></p> <p></p> <p></p> <p></p> <p></p> <p></p>	<p>REVISIONS</p> <p>1 ORIGINAL ISSUE</p> <p>2 DIMENSIONS AND PORT DETAILS ADDED.</p> <p>3</p> <p>4</p> <p>5</p> <p>6</p> <p>7</p> <p>8</p> <p>9</p>	<p>JOB No 53779</p> <p>DRAWN T.RINTS</p> <p>R.P.B.</p>	<p>All Dimensions in millimetres & refer to finished sizes</p> <p>Tolerances: -</p> <ul style="list-style-type: none"> No decimal places ± 0.4 One decimal place ± 0.1 Angular $\pm 0.5^\circ$ Squareness 0.1 per 100mm hole depths to drill point Surface texture 3.2um Remove all burrs & break sharp edges rad 0.1/0.5 unless otherwise stated 	<p>SERVOTEST © 2001</p> <p>TITLE: SERVOVALVE ASSEMBLY (SV5,10,19,38)</p> <p>MATERIAL: SEE ABOVE</p> <p>DATE: 08/10/91</p> <p>DRN: T.RINTS</p>	<p>FINISH: _____</p> <p>DRN.No. D 000-1396/9</p> <p>SCALE: 1:1</p> <p>AUTHORIZED: _____</p>
--	---	--	--	--	--	---	--	---